

---

## Advanced Technologies for Desulphurisation of Coke Oven Gas

Dr. Frank Sowa, Bjoern Otten, Johannes Kamp  
DMT GmbH & Co. KG, Cokemaking Technology Division,  
Am Technologiepark 1, 45307 Essen, Germany

Dr. Emanuele Proface  
Paul Wurth Italia S.p.A., Via di Francia 1, 16149 Genova, Italy

### 1 Abstract

Industrial processes with sulphur dioxide emissions are frequently more significant locally than fossil fuel combustion sources for power generation. One important industrial process contributing to these emissions is the coke plant with the utilisation of **Coke Oven Gas (COG)** as underfiring gas or fuel gas.

Coke oven gas contains hydrogen sulphide ( $H_2S$ ) and other sulphuric compounds like carbon disulphide ( $CS_2$ ), carbonyl sulphide (COS), mercaptans etc. The separation of these pollutants is strongly required by environmental protection.

Generally the processes suitable for desulphurisation of coke oven gas can be subdivided into different methods:

- Dry oxidation processes
- Wet oxidation processes
- Absorption/stripping processes

In the following paper only the wet oxidation and the absorption / stripping processes will be considered for comparison as they form the main types of desulphurisation processes for COG cleaning.

The common by-products from these cleaning processes are:

- Elementary Sulphur
- Sulphuric acid.

As first step this paper provides an overview of the most common desulphurisation processes and elaborates the differences in the case of the individual processes and process combinations as a function of the requirements to the gas purity and environmental protection. The overview offers a basis for concrete planning of the desulphurisation process.

As second step two common desulphurisation processes are compared in terms of technical process routes and Total Cost of Operation (TCO), i.e. capital and operational costs as well as revenues from saleable products.

## 2 Introduction

Because of its hydrogen sulphide (H<sub>2</sub>S) content (up to 9 g/Nm<sup>3</sup>) unpurified coke oven gas is unsuited for use in many industrial applications. When the gas has been desulphurised, however, its use for a variety of applications becomes potentially viable.

Many coke plants meanwhile sell coke oven gas after desulphurisation at a profit. Desulphurisation for commercial reasons coincides with the need to protect the environment from the effect of acid rain, because desulphurised coke oven gas decreases emissions of SO<sub>2</sub> at the site of coke oven gas combustion. COG desulphurisation is becoming increasingly common practice in the European Union due to the environmental legislation in force.

However, depending on the final utilisation (utilisation possibilities are shown in Figure 1 below) the grade of COG cleaning may differ distinctly (see Table 1) and will have an impact on the selection of the desulphurisation process.

Alternative Ways of Using Coke Oven Gas (COG)

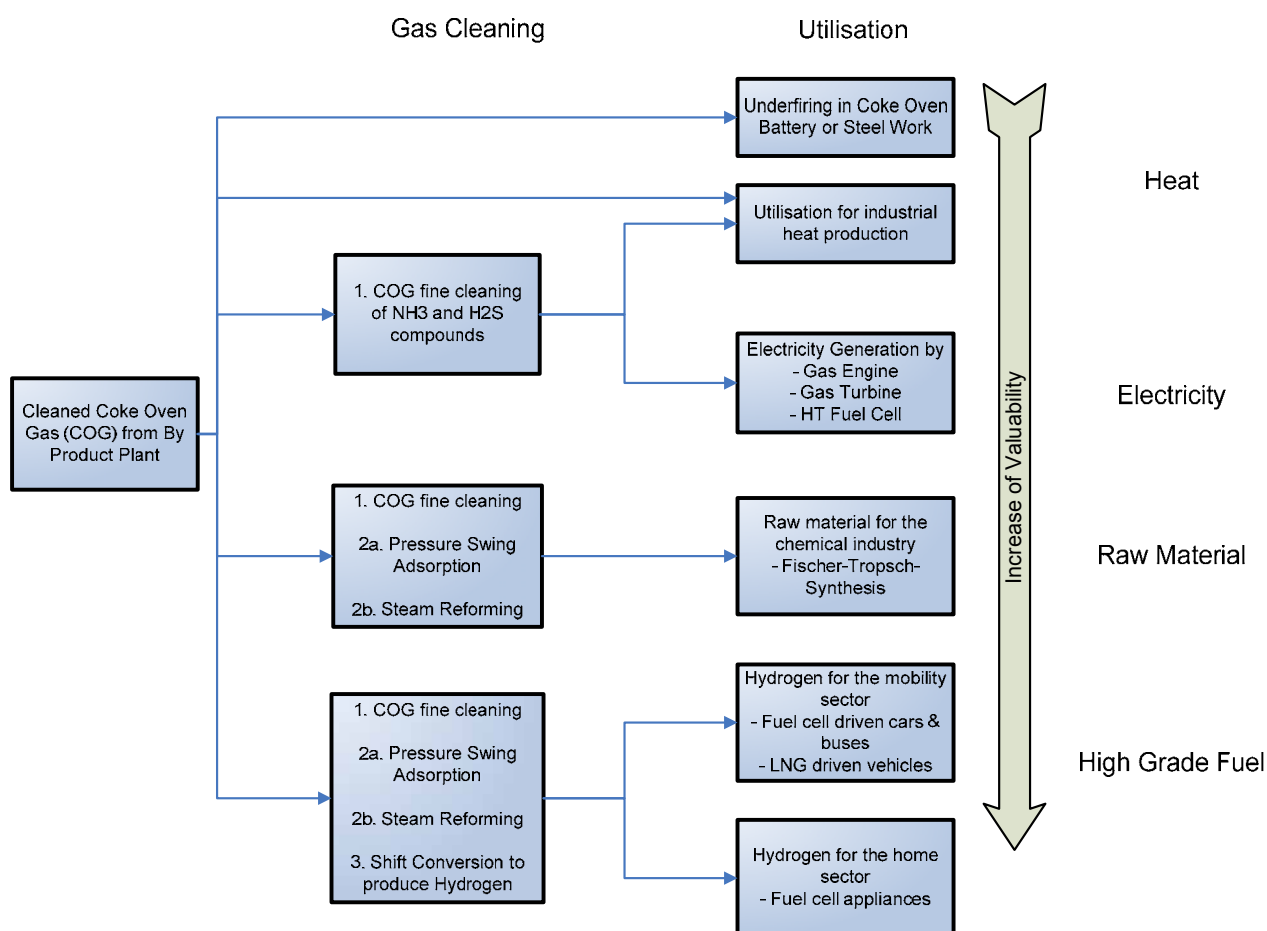

Fig. 1: Alternative Ways of Using COG

The purity requirements marked in yellow can be achieved by commonly applied cleaning technologies in by-product plants. Further deep cleaning requirements have to be considered additionally and may lead to an extension of the by-product plant.

Utilisation	NH <sub>3</sub> (mg/Nm <sup>3</sup> COG)	H <sub>2</sub> S (mg/Nm <sup>3</sup> COG)	HCN (mg/Nm <sup>3</sup> COG)
Coke Oven Underfiring	< 10 – 200	< 300 – 900	< 500 – 1000
Industrial Boilers	< 10 – 200	< 300 – 500	< 500 – 1000
Gas Motor	< 15	< 300 – 500	unspecified
Low efficient Gas Turbine	unspecified	< 500	unspecified
High efficient Gas Turbine (e.g. for Combined Cycle)	< 0,3	< 1,2	< 7,0
HT Fuel Cell	< 0,5	< 2,0	< 150
Fischer Tropsch Synthesis	< 1 ppmV	H <sub>2</sub> S + COS + CS <sub>2</sub> < 1 ppmV	< 1 ppmV

**Tab. 1: Purity Requirements for COG depending on the utilisation of COG**

Typical desulphurisation processes to clean COG down to certain levels of H<sub>2</sub>S will be presented and compared in the following chapter.

### 3 Overview of Desulphurisation Processes

Generally the processes suitable for desulphurisation of COG can be subdivided into different methods:

1. Dry oxidation processes
2. Wet oxidation processes
3. Absorption/stripping processes

Wet oxidative processes		Absorption / stripping processes	
Name	Description	Name	Description
Stretford	H <sub>2</sub> S is scrubbed from the coke oven gas by a sodium carbonate solution (Na <sub>2</sub> CO <sub>3</sub> ) and elemental sulphur (S <sup>0</sup> ) is yielded using vanadate (VO <sub>3</sub> ) as an intermediate. Regeneration of the scrubbing liquid takes place by aeration (O <sub>2</sub> ), using anthraquinone disulphonic acid (ADA) as an intermediate.	ASK* or Diamex	H <sub>2</sub> S is scrubbed from the coke oven gas by a NH <sub>3</sub> solution. The NH <sub>3</sub> solution is derived from the NH <sub>3</sub> scrubber. The H <sub>2</sub> S and NH <sub>3</sub> are stripped from the washing liquor by steam stripping and the vapours are led to a Claus plant or a sulphuric acid plant.
Takahax	Similar to the Stretford process, except that 1,4-naphthoquinone-2-sulphonic acid is used as an intermediate for the regeneration.	Vacuum Carbonate	H <sub>2</sub> S (and also HCN and CO <sub>2</sub> ) is scrubbed from the COG with a sodium carbonate solution or a potassium carbonate solution (Na <sub>2</sub> CO <sub>3</sub> or K <sub>2</sub> CO <sub>3</sub> ). The potassium variant allows higher carbonate concentrations. The washing liquor is regenerated in a column, using high temperature and low pressure (0.12-0.14 bar). Acid gases are stripped from the liquor and can be treated in a Claus plant or a sulphuric acid plant.
Thylox	Sodium thioarsenate (Na <sub>4</sub> As <sub>2</sub> S <sub>5</sub> O <sub>2</sub> ) binds the H <sub>2</sub> S and regeneration is done by oxygen treatment. Elemental sulphur is yielded.	Sulfiban	Coke oven gas is scrubbed with monoethanolamine (MEA). NH <sub>3</sub> removal prior to H <sub>2</sub> S removal is necessary to avoid pollution of the washing liquor. H <sub>2</sub> S is stripped from the MEA solution using steam and can be treated in a Claus plant or a sulphuric acid plant. Insoluble organic S-compounds are removed from the MEA solution as solid waste.
Perox	The gas is scrubbed with an ammonia solution. Parabenzoquinone is used for sulphur oxidation and regeneration of the scrubbing liquor is done by oxygen.	DESULF	Virtually the same as the ASK-process, but the NH <sub>3</sub> is removed from the NH <sub>3</sub> / H <sub>2</sub> S vapour in saturators, producing ammonium sulphate ((NH <sub>4</sub> ) <sub>2</sub> SO <sub>4</sub> ).
Fumaks-Rhodacs	H <sub>2</sub> S is oxidised by picric acid in the Fumaks-phase, yielding elemental sulphur. Cyanides are recovered in the Rhodacs phase.		

**Tab. 2: Coke oven gas desulphurisation processes and their characteristics**<sup>1</sup>  
\*ASK = Ammoniumsulphide Circuit Scrubber (Ammoniumsulphid-Kreislaufwäscher)

<sup>1</sup> European Commission, DG JRC, 2000, "Integrated Pollution Prevention and Control (IPPC) – Best Available Techniques Reference Document on the Production of Iron and Steel", Chapter 6, Coke Oven Plants

Here, only the wet oxidation and the absorption / stripping processes will be considered for comparison as they form the main types of desulphurisation processes for COG cleaning.

In Europe, the most commonly applied process is the absorptive process using an ammonia liquor to scrub the H<sub>2</sub>S from the coke oven gas (Ammoniumsulphide Kreislaufwäsche (ASK) process or Diamex). The discharge of small wastewater flows to the biological treatment plant does not require any further treatment.

The most commonly applied wet oxidative process (outside Europe) is the Stretford process. It is applicable in a wide range of desulphurisation capacities from 400 to 110,000 Nm<sup>3</sup>/h COG.

Coke oven gas desulphurisation of both the wet oxidative and the absorptive type can be applied at new and existing plants. The choice depends on the cleaned coke oven gas specifications, environmental considerations, the integration within the gas cleaning plant, etc.

Wet oxidative processes have a better desulphurisation efficiency than absorptive processes. Wet oxidative processes can have an efficiency of >99.9% achieving residual H<sub>2</sub>S concentrations as low as 1 mg/Nm<sup>3</sup> in the coke oven gas. Absorptive processes do not usually exceed 95% desulphurisation efficiency and residual H<sub>2</sub>S concentrations in the coke oven gas are usually around 500 mg/Nm<sup>3</sup> COG.

However, any wet oxidative process used for desulphurising coke oven gas will also remove most of the hydrogen cyanide from the coke oven gas and form sodium thiocyanide by the following reaction:

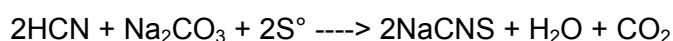

The sodium thiocyanide and the small amounts of sodium sulphate and thiosulphate formed by side reactions are not regenerated by the process and build up in the circulating liquor.

It is therefore necessary to purge a liquid stream to prevent salting out of the chemicals. In the case of the Stretford process, this discharge flow contains vanadium compounds, quinone and hydroquinone compounds (from ADA), thiocyanide and thiosulphate. Discharge of these components is undesirable from an environmental and economic point of view (water pollution and loss of expensive chemicals).

To reduce chemical consumption cyanic acid (HCN) can be removed prior to desulphurisation in a pre-washer using a sodium polysulphide or ammonium polysulphide solution. Pre-removal of HCN does not reduce the total volume of effluent produced.

Wastewater from wet oxidative desulphurisation processes is usually treated separately owing to the presence of compounds that have a detrimental effect on the biological wastewater treatment plant. In principle the following alternative methods have been developed in pilot scale and could be applied for the treatment of the wastewater purge stream:

- Evaporative or spray drying
- Biological degradation
- Oxidative combustion
- Reductive incineration

## 4 COG Cleaning Plant Configuration for TCO Considerations

For the elaboration of the Total Cost of Operation (TCO) the Stretford process and the ASK process - representing the most common processes of their classes - will be taken into closer consideration.

In order to properly prepare the TCO comparison the boundaries of the processes have to be adjusted correctly. As the ASK process uses  $\text{NH}_3$  scrubbing liquor and the Claus plant is designed also to crack  $\text{NH}_3$  and HCN from the stripped  $\text{NH}_3$  /  $\text{H}_2\text{S}$  vapours in addition to sulphur production, the Stretford process has to be extended by an Ammoniumsulphate Unit taking care for the  $\text{NH}_3$  in the COG prior to desulphurisation.

Hence, the correct plant configurations for TCO comparison read as follows:

Wet oxidative process		Absorption / stripping process	
Name	Description	Name	Description
Ammonium Sulphate Unit / Stretford Unit	$\text{H}_2\text{S}$ is scrubbed from the coke oven gas by a sodium carbonate solution ( $\text{Na}_2\text{CO}_3$ ) and elemental sulphur ( $\text{S}^\circ$ ) is yielded using vanadate ( $\text{VO}_3$ ) as an intermediate. Regeneration of the scrubbing liquid takes place by aeration ( $\text{O}_2$ ), using anthraquinone disulphonic acid (ADA) as an intermediate.	ASK* Unit / Claus Unit	$\text{H}_2\text{S}$ is scrubbed from the coke oven gas by a $\text{NH}_3$ solution. The $\text{NH}_3$ solution is derived from the $\text{NH}_3$ scrubber. The $\text{H}_2\text{S}$ and $\text{NH}_3$ are stripped from the washing liquor by steam stripping and the vapours are led to a Claus plant.
	Configuration: <ul style="list-style-type: none"> <li>• Ammoniumsulphate Unit (Spray Type or Bubble Type Saturator)</li> <li>• Stretford Unit</li> </ul>		Configuration: <ul style="list-style-type: none"> <li>• <math>\text{H}_2\text{S}</math> / <math>\text{NH}_3</math>-Scrubbing Unit (ASK)</li> <li>• Distillation Unit (Stripper- / Deacidifier Unit)</li> <li>• Claus-Plant (Combined <math>\text{NH}_3</math>-Cracking / Elementary Sulphur Unit)</li> </ul>
	By-Products: <ul style="list-style-type: none"> <li>• Ammoniumsulphate (<math>(\text{NH}_4)_2\text{SO}_4</math>)</li> <li>• Elementary Sulphur (<math>\text{S}^\circ</math>)</li> </ul>		By-Product: <ul style="list-style-type: none"> <li>• Elementary Sulphur (<math>\text{S}^\circ</math>)</li> </ul>

**Tab. 3: COG Cleaning Plant Configuration**  
 \*ASK = Ammoniumsulfide Circuit Scrubber (Ammoniumsulfid-Kreislaufwäscher)

In order to allow a technological comparison the respective units of the configurations are described in more detail in the following chapters. Please note that all units have been described without redundancies of the main process equipment.

### 4.1 Description of the Absorption / Stripping Process

Generally, for the ASK process three consecutive process steps are required: as first step the scrubbing of the sulphur and ammonia compounds from the COG to produce a fuel gas with low sulphur and ammonia concentration, as second step the extraction of sulphur, ammonia and cyanide compounds from the scrubbing liquor and as third step the conversion of the toxic vapours into harmless but valuable by-products.

The basis of comparison is the  $\text{NH}_3/\text{H}_2\text{S}$  scrubbing unit in combination with a stripper-deacidifier unit and a Claus Plant. The Claus Plant is designed as a combination of an Ammonium Cracking and an Elementary Sulphur Plant.

As standard performance a concentration of less than  $30 \text{ mg/Nm}^3 \text{ NH}_3$  and  $450 \text{ mg/Nm}^3 \text{ H}_2\text{S}$  can be achieved in the cleaned coke oven gas. With an addition of caustic soda in the lower section of the  $\text{H}_2\text{S}$ -scrubber a concentration of  $300 \text{ mg /Nm}^3 \text{ H}_2\text{S}$  will be achieved.

With additional efforts a  $\text{H}_2\text{S}$  concentration of less than  $2 \text{ mg /Nm}^3$  can be reached to fulfil the requirements of a clean fuel gas. However, these additional efforts are not considered in this TCO comparison.

After the “zero-emission” Claus Plant the impurities of the crude coke oven gas ( $\text{NH}_3$ ,  $\text{H}_2\text{S}$ , HCN) are converted in Nitrogen ( $\text{N}_2$ ), Hydrogen ( $\text{H}_2$ ), Sulphur (S), Carbonmonoxide (CO) and Carbondioxide ( $\text{CO}_2$ ).

#### 4.1.1 $\text{H}_2\text{S} / \text{NH}_3$ - Scrubbing Unit (ASK\*)

Following the COG gas line, the COG is directed to the  $\text{H}_2\text{S}/\text{NH}_3$  - scrubbing system (see figure below). As can be seen from the schematic flow diagram, the COG flows sequentially through the  $\text{H}_2\text{S}$ -scrubber and the  $\text{NH}_3$ -scrubber.

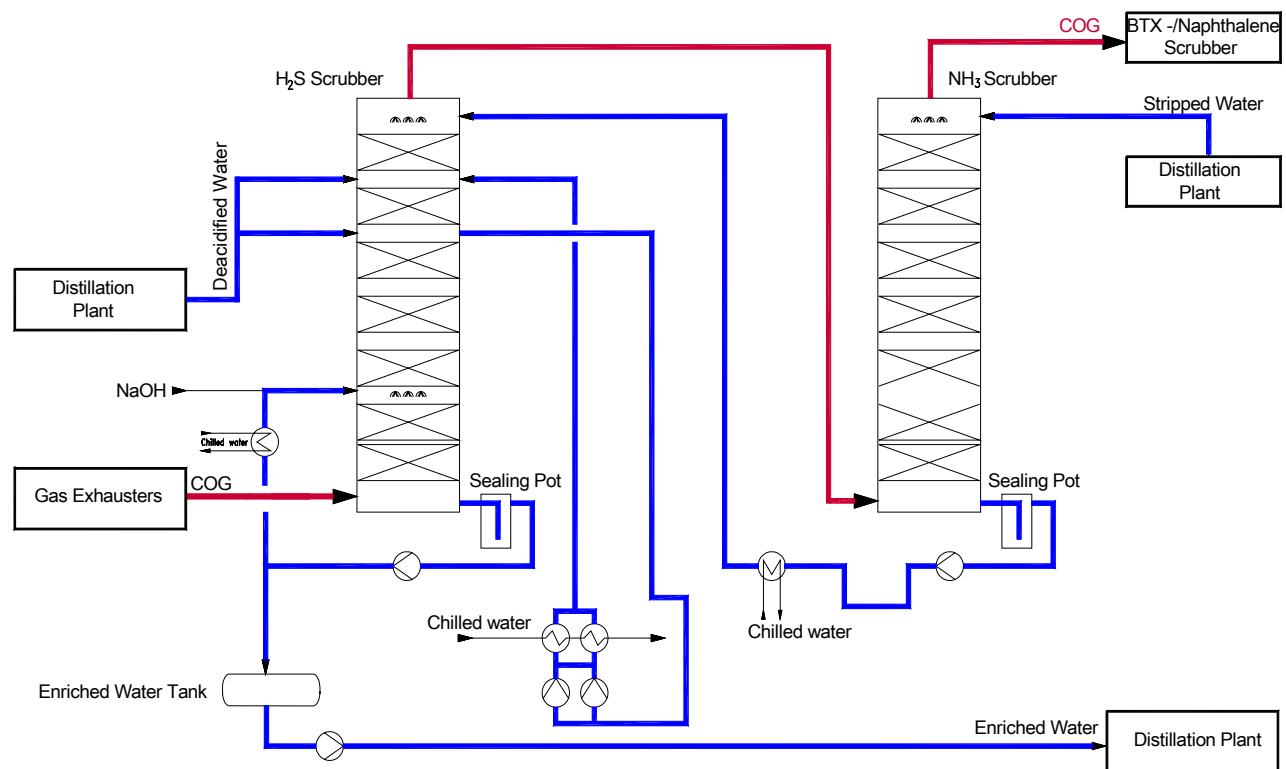

**Fig. 2:  $\text{H}_2\text{S} / \text{NH}_3$ -Scrubbing Unit**  
**\*ASK = Ammoniumsulphide Circuit Scrubber (Ammoniumsulfid-Kreislaufwäscher)**

First, the COG is led into the  $\text{H}_2\text{S}$ -scrubber and flows bottom-up. Entering the lower part of the  $\text{H}_2\text{S}$ -scrubber, the COG is cooled by sprinkling with washing water in order to remove the energy coming from gas exhauster compression. Discharging the  $\text{H}_2\text{S}$ -scrubber, a part of the washing water is led through a cooling loop, comprising of pumps and heat exchangers. By that a part of

the washing water is indirectly cooled with chilled water and then recycled into the lower scrubbing section of the scrubber.

The upper area of the H<sub>2</sub>S-scrubber is used to remove the major H<sub>2</sub>S content of the COG. The absorption of H<sub>2</sub>S is performed by NH<sub>3</sub>, which is on the one hand included in the COG and otherwise additionally fed by deacidified water entering in the upper part of the H<sub>2</sub>S-scrubber provided by the deacidifier. Furthermore, the scrubbing process is carried out by spraying with pre-enriched NH<sub>3</sub>-water entering at the top of H<sub>2</sub>S-scrubber coming from the ammonia scrubber.

Due to the exothermic absorption of NH<sub>3</sub> and H<sub>2</sub>S within the H<sub>2</sub>S-scrubber, the reaction heat has to be removed by an internal cooling section. For that, a part of the washing liquor is discharged from the upper area of the scrubber and fed by pumps through intermediate heat exchangers and indirectly cooled with chilled water. Leaving these coolers, the washing liquor is returned into the upper part of the H<sub>2</sub>S-scrubber.

The further removal of H<sub>2</sub>S and the removal of the major portion of ammonia is performed in the NH<sub>3</sub>-scrubbing system. The NH<sub>3</sub> scrubbing process is carried out by means of stripped ammonia water coming from a stripped water tank. The stripped water flows top-down through the NH<sub>3</sub>-scrubber whereas the COG enters the scrubber and flows bottom-up to the outlet at the top. For removing the energy of the exothermic absorption process, the pre-enriched water, leaving the NH<sub>3</sub>-scrubber, is indirectly cooled by chilled water and led to the top of the H<sub>2</sub>S-scrubber. Finally, the COG is directed to the BTX-/Naphthalene scrubbing system.

The enriched water is released from the bottom of the H<sub>2</sub>S scrubber to the enriched water buffer tank by gravity before the water is discharged to the stripper/deacidifier of the distillation plant. For releasing the washing liquor behind each scrubber a sealing pot is installed.

### Chemistry of the scrubbing process

in NH<sub>3</sub> scrubber:



in H<sub>2</sub>S scrubber:

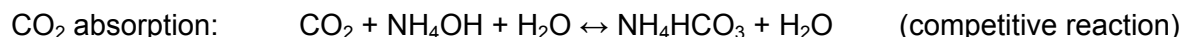
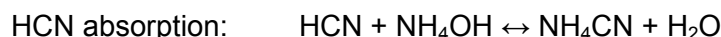
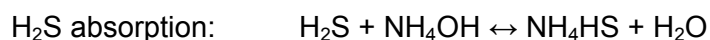

#### 4.1.2 Distillation Unit (Stripper / Deacidifier Unit)

The distillation plant, consisting of stripper- and deacidifier columns (see figure below) is installed to reduce and to remove, respectively, the gaseous components H<sub>2</sub>S, NH<sub>3</sub>, HCN, CO<sub>2</sub> from the washing liquor leaving the NH<sub>3</sub>-/H<sub>2</sub>S- scrubbers. Besides, in this plant the scrubbing liquors are prepared for recycling into the NH<sub>3</sub> scrubber as well as the deacidified water for the H<sub>2</sub>S scrubber.

Generally, two columns have to be installed, one stripper for ammonia and one deacidifier.

The enriched water, leaving the enriched water tank, is indirectly preheated in heat exchangers with hot stripped and hot deacidified water, sequentially, coming from the stripper and the deacidifier. Then it is fed to the top of the deacidifier. This enriched water flows top-down in counter flow to the rising steam and  $\text{NH}_3$  containing vapours, coming from the stripping process. The vapours leaving the deacidifier, comprising the main part of stripped  $\text{H}_2\text{S}$ ,  $\text{CO}_2$  and  $\text{HCN}$  as well as  $\text{NH}_3$ , are directed to a vapour condenser with downstream condensate strainer. While the condensate is returned to the deacidifier, the vapours are led to the Claus Plant.

Having discharged the sump of the deacidifier, a part of the deacidified water is pumped to the  $\text{NH}_3$ -stripper (upper part of the stripper column). The other part of deacidified water is fed via heat exchanger groups into the deacidified water tank. In the first heat exchanger group the deacidified water is cooled indirectly with the input of enriched water of deacidifier. In the second heat exchanger the further cooling of deacidified water is carried out indirectly by cooling water. Flowing out of the intermediate tank, the deacidified water is led to the  $\text{H}_2\text{S}$  scrubber after passing a further cooler operated indirectly with chilled water.

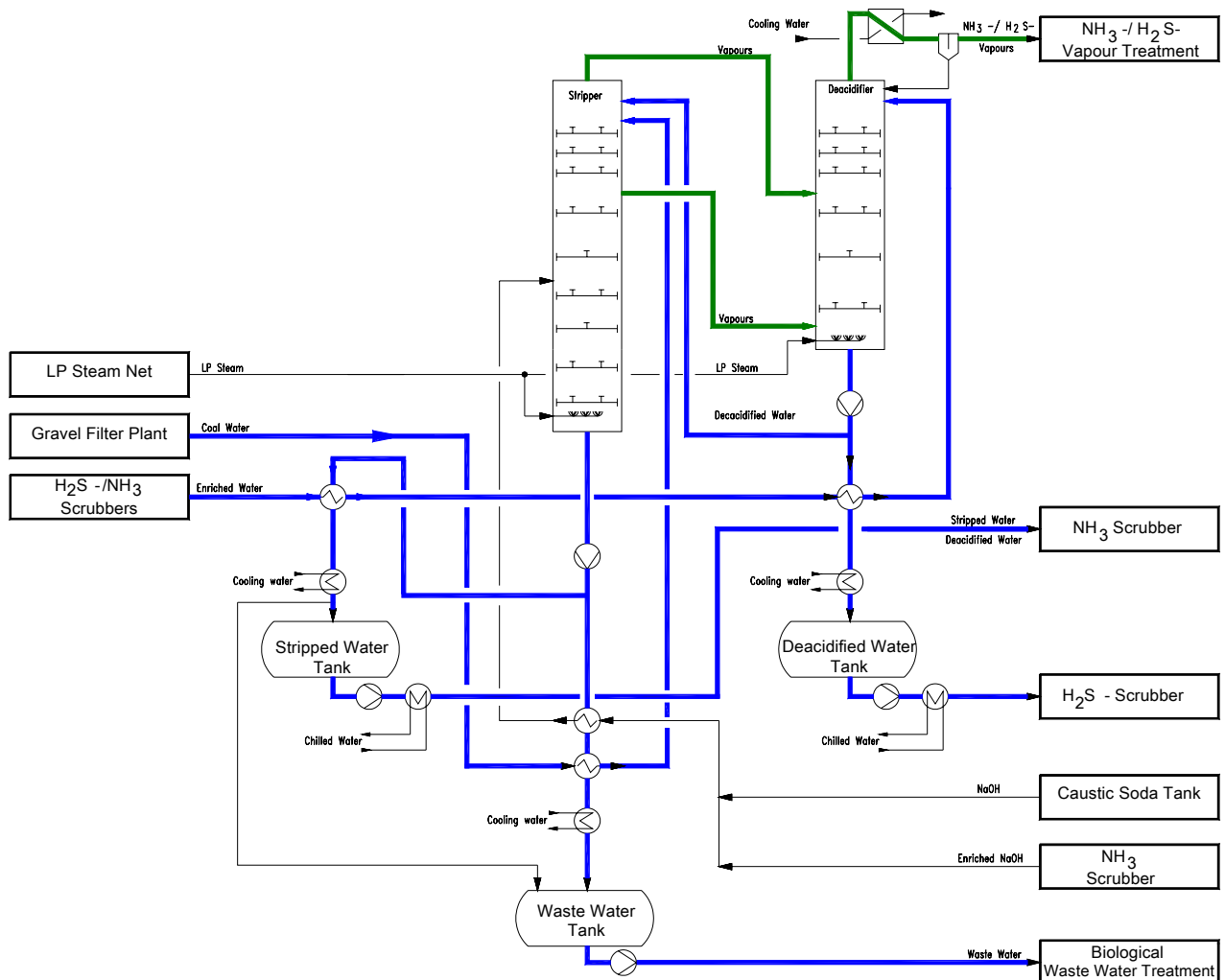

**Fig. 3: Stripper / Deacidifier Plant**

After the inlet to the  $\text{NH}_3$ -stripper, the deacidified water flows top-bottom in counter flow to low-pressure steam, which is added via a steam sprinkler at the sump of the upper part of the combined distillation column. The  $\text{NH}_3$ -comprising vapours, streaming out at the top of  $\text{NH}_3$ -

stripper, are directed to the midsection of the deacidifier, while the middle part vapours of the stripper are introduced above the bottom of the deacidifier. Leaving the sump of NH<sub>3</sub>-stripper, the stripped water is fed through heat exchanger groups. Passing the first one, the stripped water is indirectly cooled with cold enriched water, which flows to the deacidifier. Then, within the other heat exchanger group, the stripped water is cooled indirectly against cooling water. One part of the cooled stripped water, corresponding to the mass flow of steam added in the NH<sub>3</sub>-stripper, is directed to the waste water tank. After intermediate storage, the other part of cooled stripped water is fed to the NH<sub>3</sub> scrubber, via an indirectly operated chilled water cooling stage.

The distillation of coal water, leaving the gravel filter plant, is carried out in the NH<sub>3</sub>-stripper by addition of low-pressure steam at the bottom of the stripper column. Caustic soda addition at the lower third of the column serves to destroy the fixed ammonia compounds.

After leaving the NH<sub>3</sub>-stripper, in downstream heat exchangers, the hot stripped coal water is indirectly cooled against caustic soda and cold coal water which is fed to the inlet of the NH<sub>3</sub>-stripper. A final cooling of the stripped coal water is done indirectly against cooling water, before it is collected in the waste water tank. The waste water including the excess stripped water of NH<sub>3</sub>-stripper is directed to the biological waste water treatment plant. No further intermediate treatment is required.

### **Chemistry of the stripping process**

#### in NH<sub>3</sub> stripper:

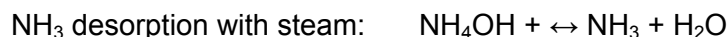

#### in H<sub>2</sub>S stripper (deacidifier):

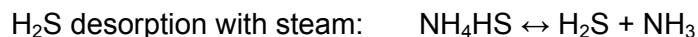

### **4.1.3 Claus-Plant (Combined NH<sub>3</sub>-Cracking / Elementary Sulphur Unit)**

For processing the H<sub>2</sub>S/NH<sub>3</sub> vapours coming from the distillation plant, a combined ammonia cracking/elementary sulphur plant (see schematic flow diagram below) is provided. There are some process configurations to operate such a plant. In the following a process with a 2-stage Claus reactor is described.

Under the top pressure of the deacidifier and ammonia stripping system, the H<sub>2</sub>S/NH<sub>3</sub>-vapours are led to the burner system of the cracking reactor. Operating at sub-stoichiometrical combustion conditions at a proper temperature for reaction, a certain ratio of H<sub>2</sub>S is burned to SO<sub>2</sub>. The combustion air is supplied by an air blower and directed into the burner system. Especially, for start-up operation and after process interruptions partly cleaned COG or natural gas is used for heating up and stabilising the combustion. The COG/natural gas is supplied by a gas blower.

Inside the catalyst bed of the crack reactor the NH<sub>3</sub> and HCN compounds of the vapours are cracked. Downstream of the catalytic bed secondary air is supplied to adjust the stoichiometrical ratio of H<sub>2</sub>S/SO<sub>2</sub> for the reaction in the following Claus reactor.

The hot process gas leaves the crack reactor and passes the waste heat boiler system. In this boiler system the process gas is indirectly cooled by generating steam via boiler feed water. The parameters of the produced steam can be selected in a certain range. As shown in the flow diagram, it is proposed to generate HP-steam in combination with LP steam. During cooling down of the process gas within the LP boiler, the first sulphur is condensed. After separation it is directed to the sulphur sealing pot.

By mixing the outlet gas of the HP boiler with the outlet of the LP boiler the required inlet temperature to the 1<sup>st</sup> Claus reactor stage is adjusted. Within the first and second stage of Claus reactors, the process gas passes a catalyst bed. By that, the reaction between SO<sub>2</sub> and H<sub>2</sub>S takes place to produce liquid elementary sulphur (S<sub>x</sub>) plus H<sub>2</sub>O.

Leaving the first stage of the Claus reactor, the process gas is directed to the first stage of a sulphur condenser. Similar to the LP boiler, the process gas is indirectly cooled by boiler feed water generating LP steam. Then the process gas passes a separator for precipitation of the condensed sulphur. While the liquid sulphur is led to the sulphur sealing pot, the process gas flows to a downstream gas heater. Using produced HP steam of the HP boiler, the process gas is indirectly reheated up to conversion temperature for the Claus reaction. After reheating the process gas is led to the second stage of the Claus reactor to convert more H<sub>2</sub>S/SO<sub>2</sub> and to produce further sulphur according to above mentioned reaction. Subsequently, in the second stage of the sulphur condenser the gas is indirectly cooled while LP steam is generated. After cooling the process gas and sulphur precipitation in the downstream separator, the process gas (tail gas) with residual contents of SO<sub>2</sub> and H<sub>2</sub>S, is directed to the crude gas collection main in front of the PGC. Leaving the separator, the sulphur flows into the sulphur sealing pot.

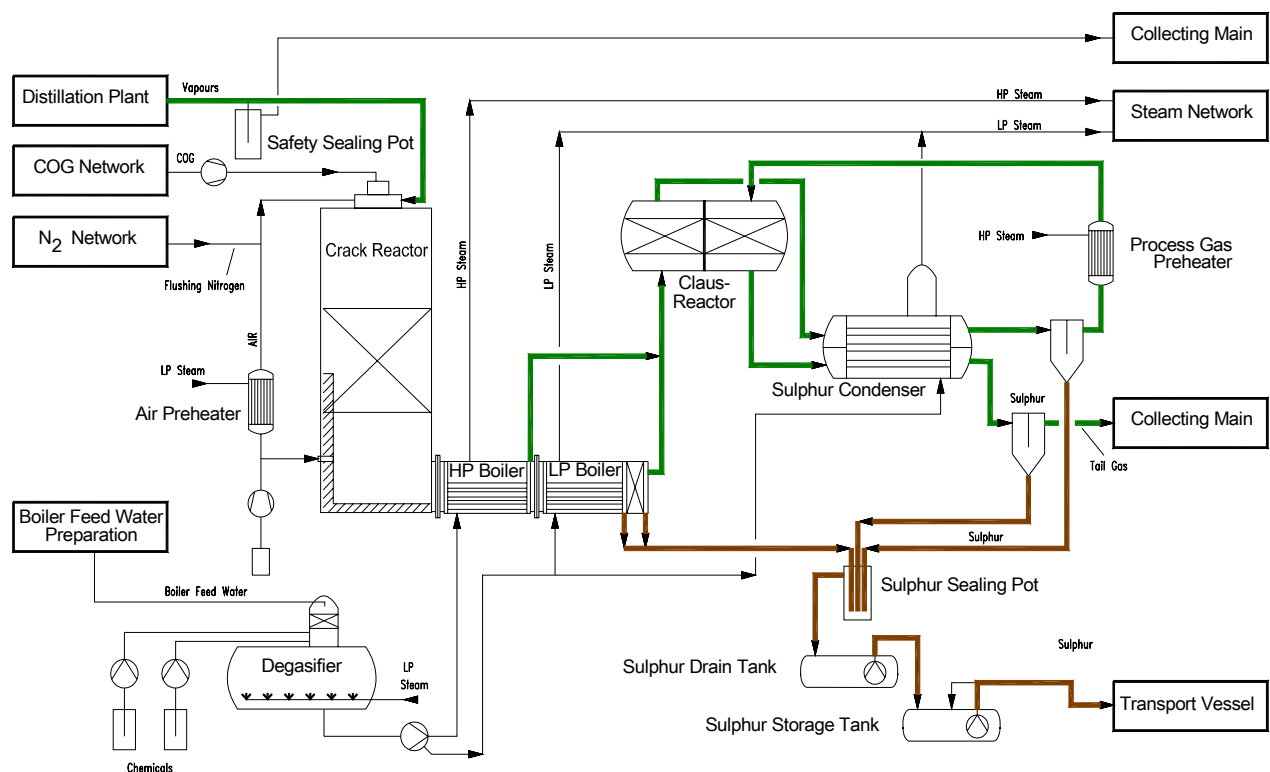

**Fig. 4: Combined NH<sub>3</sub>-Cracking/Elementary Sulphur Plant**

The produced liquid sulphur (bright yellow and of high quality >99.5%), firstly collected in the sulphur sealing pot, is discharged into a sulphur drain tank and from there pumped to the sulphur storage tank. Both, the sulphur drain and the storage tanks are steam heated by coils. Periodically, the liquid sulphur is fed into transport vessels for distribution to further disposal by a loading station. Optionally, the liquid sulphur may also be discharged to a solidification unit to produce sulphur pellets.

The surplus steam, produced in HP-/LP-boiler and sulphur condenser, is led to the steam distribution network for further utilisation.

### **Chemistry of the NH<sub>3</sub> cracking / Claus process**

in vapour burner:

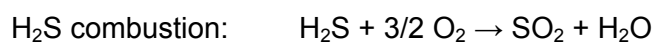

in crack reactor with catalyst:

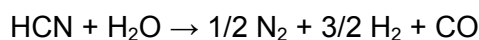
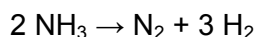

in Claus reactor with catalyst:



## **4.2 Description of the Wet Oxidation Process Route**

The second process identified for the comparison in terms of technical process routes and Total Cost of Operation (TCO) as mentioned in the abstract is the Stretford process. In order to properly prepare the TCO comparison the boundaries of the two processes have to be adjusted correctly. As the ASK process uses NH<sub>3</sub> scrubbing liquor and the Claus plant is designed also to crack NH<sub>3</sub> and HCN from the stripped NH<sub>3</sub> / H<sub>2</sub>S vapours in addition to sulphur production, the Stretford process has to be extended by an Ammoniumsulphate Unit taking care for the NH<sub>3</sub> in the COG prior to desulphurisation.

### **4.2.1 Ammonium Sulphate Production Plant**

The conversion of ammonia from COG with sulphuric acid to ammonium sulphate is carried out in a so-called spray type or bubble type saturator. The formation of ammonium sulphate occurs by means of neutralization of sulphuric acid with ammonia. In the following a spray type saturator process is described.

For this, the COG is directed into the spray type saturator. The ammonium sulphate lye inside the saturator is continuously sprayed into the COG in order to wash out the NH<sub>3</sub>.

The water saturated COG containing H<sub>2</sub>S-/HCN is leaving the saturator with a temperature of approx. 95 °C at the top. After a downstream arranged vapour cooler with inside drop separators

the vapours are cooled down to a temperature of approximately 60 °C and flow to the Stretford unit.

The circulating ammonium sulphate lye inside the saturator is directed via overflow pots and circulating pumps back to the saturator to protect the lye inside the saturator against clogging. Discontinuously, a stream from the bottom of the saturator is taken out by means of an ejector and flows via the slurry cone to the centrifuge. Inside the centrifuge the sulphate grains are cleaned from the diluted sulphuric acid, dewatered and dried in a steam heated dryer and stored in a salt store.

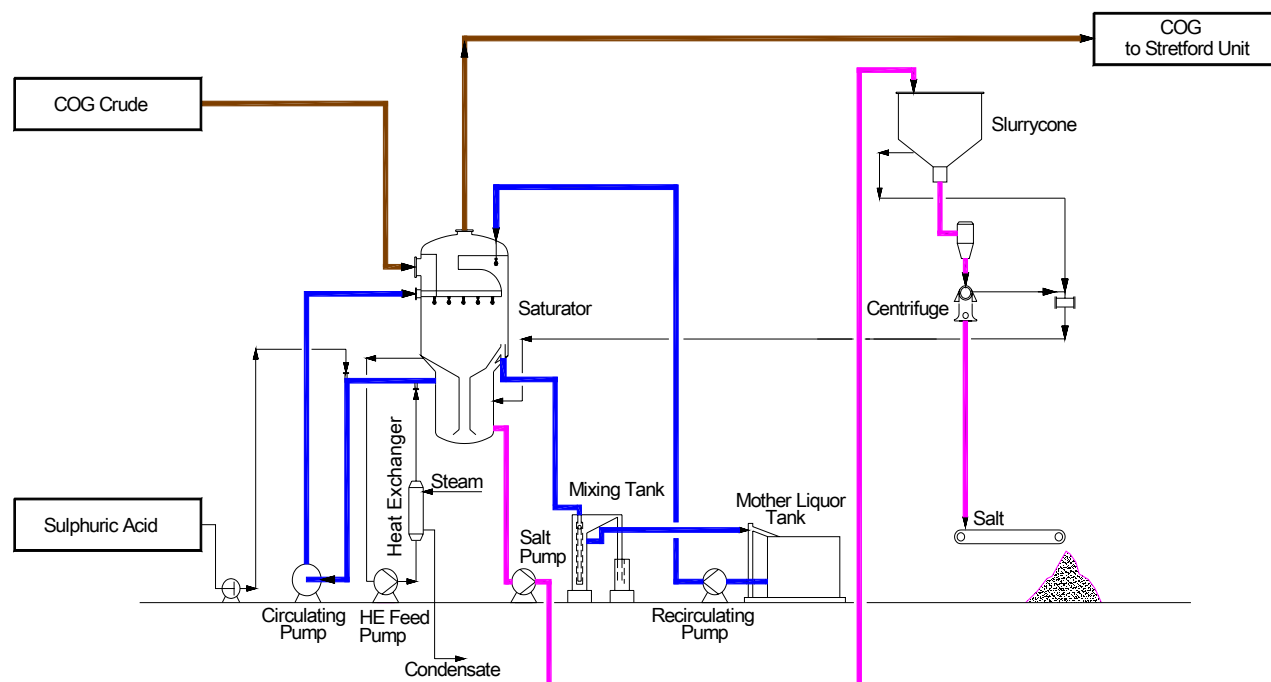

**Fig. 5: Ammonium Sulphate Production Plant**

## Chemistry of the ammoniumsulphate process

in saturator:



### 4.2.2 Stretford Plant

A schematic flow diagram of a typical low-pressure Stretford unit is shown in the figure below.

As HCN reacts in an irreversible manner with the Stretford chemicals separation of HCN has to be performed prior to the Stretford desulphurisation process in order to reduce the consumption of chemicals. However, introducing a separate HCN-scrubber leads to higher capital costs on the other side. A special scrubbing liquor consisting of sodium polysulfide solution has to be prepared in a polysulfide generator. In order to prepare the polysulfide solution a part of the generated sulphur has to be separated from the production quantity in the oxidiser and introduced to the polysulfide generator. A small purge stream has to be taken out from the generator in order to prevent build-up of NaCNS and other salts resulting from side reactions.

After passing the HCN-scrubber in a countercurrent flow the COG is contacted countercurrently with the Stretford solution in the H<sub>2</sub>S-scrubber, where practically all the hydrogen sulfide is removed. The treated gas may contain less than 1 ppm of hydrogen sulfide. The rich solution flows from the scrubber to the bottom of the scrubber, where the conversion of hydrosulfide to elemental sulphur is completed. The sulphur precipitates in the form of fine particles. From the scrubber the solution flows to the oxidiser, where it is regenerated by intimate contact with air. In the oxidizer, the sulphur is separated from the solution by flotation, and is removed at the top as a froth containing about 5 – 8 % solids. The regenerated solution, containing typically less than 0.5 wt % suspended sulphur, is recycled to the scrubber.

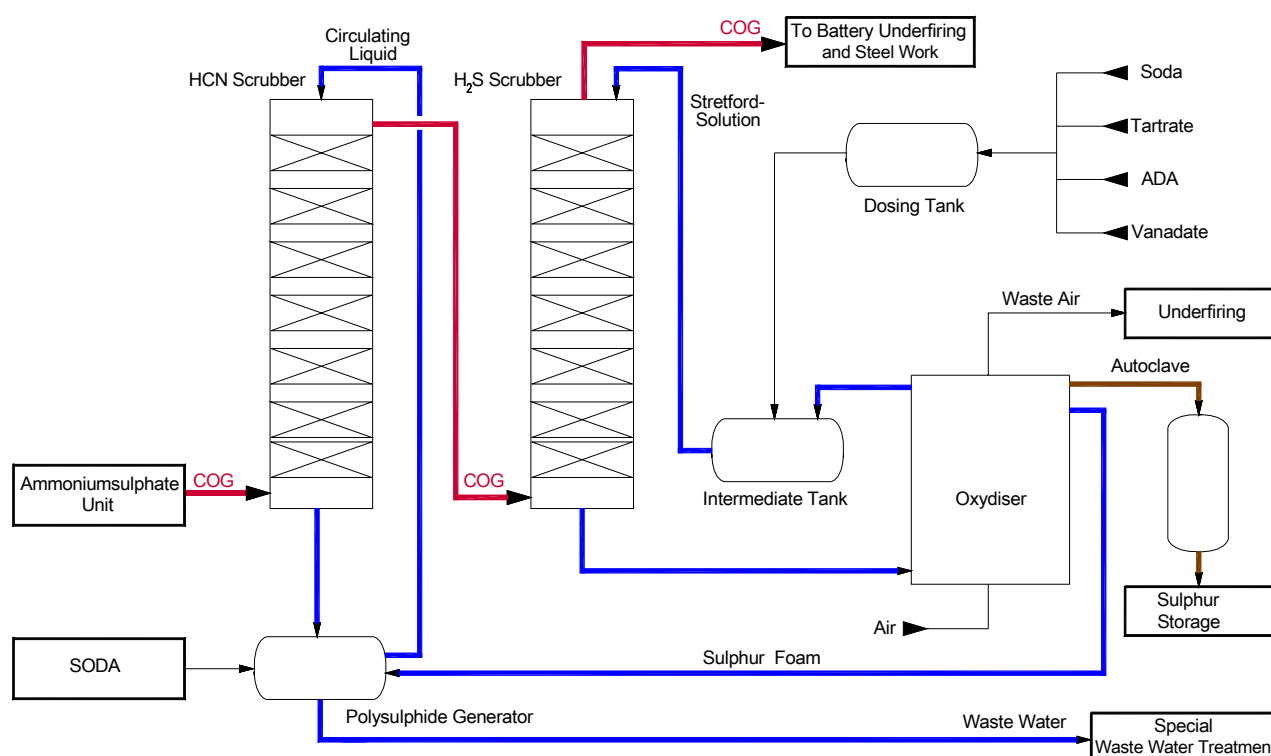

**Fig. 6: Stretford Plant**

The sulphur froth is collected and subsequently processed in a centrifuge to remove the solution remaining in the froth. The sulphur cake will be further processed by melting batchwise in a pressurized stainless-steel autoclave. Internal steam coils heat the sulphur plus the interstitial liquid to reduce its viscosity without reaching the boiling point of the mixture. The total melting operation can take up to 20 hours, with half of the time needed for sulphur melting, and the remaining time required to separate the molten sulphur from the residual liquor. The supernatant liquor phase, which contains almost all the Stretford solution chemicals, is returned to the oxidizer vessel. In this manner high grade liquid or solid sulphur is produced.

The molten sulphur phase is discharged from the bottom of the autoclave into a heated sulphur pit. The purity of the recovered molten sulphur obtained with this method depends primarily on the quality of the wet sulphur-cake introduced in the autoclave.

Sulphur can be shipped in the molten state in tank cars or trucks, but the safest and most convenient means of transportation is in solid form. This is most commonly accomplished by pelletizing the sulphur.

Several Stretford process waste streams require careful consideration. These waste streams include:

- Gas streams: treated gas when vented, oxidizer vent gas, evaporator off-gas
- Liquid streams: Stretford liquor bleed, HCN unit bleed, sulphur melting water-phase bleed

### Chemistry of the Stretford process

After scrubbing out the cyanides in the pre-scrubber the desulphurisation reaction can generally be summarised by the following process steps:

- Absorption of H<sub>2</sub>S by the basic scrubbing liquor
- Oxidation of H<sub>2</sub>S to elemental sulphur by the vanadate
- Re-oxidation of the vanadate by the ADA

#### in HCN pre-scrubber:

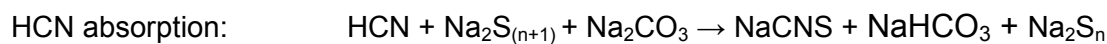
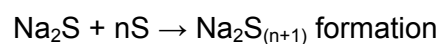

#### in H<sub>2</sub>S scrubber:

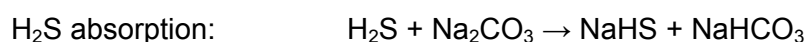

#### in scrubber / oxidiser:

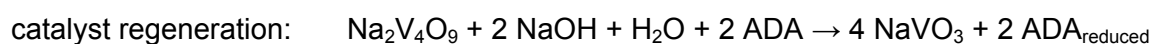

#### Side reactions (Thiosulphate and Sulphate formation)

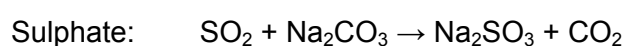
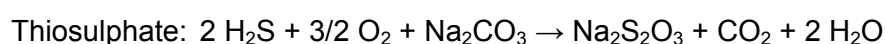

Catalyst Cycle<sup>2</sup> :

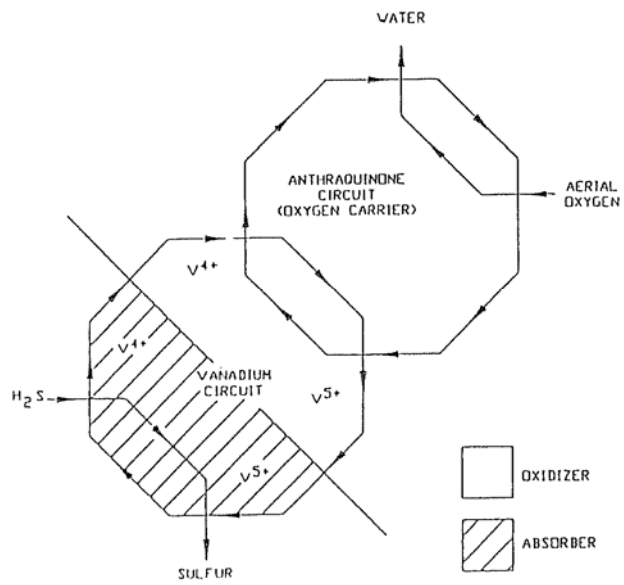

<sup>2</sup> Kohl, A., Nielsen, R., 1997, „Gas Purification, 5th Edition“, ISBN-13: 978-0-88415

## 5 Comparison of Total Cost of Operation (TCO) between the ASK / Stripping / Claus Process and the Ammonium Sulphate / Stretford Process

For the TCO comparison of the two processes the system configurations displayed in the figure below have been selected.

Stripping of coal water has been considered for TCO in both configurations. It leads to an additional stripping column in the Stretford configuration, whereas in the ASK process the coal water is stripped in the already existing stripper column. Addition of caustic soda is required in both cases to strip fix ammonia.

Moreover, a BTX/Naphthalene scrubber has to be taken into account between the Ammoniumsulphate and the Stretford unit. As this is also a requirement for the ASK process after the NH<sub>3</sub> scrubber the BTX/Naphthalene scrubber has not been considered for TCO evaluation in both configurations.

The basis for the TCO evaluation is a by-product plant handling 42,000 Nm<sup>3</sup> COG / h containing 6 g H<sub>2</sub>S / Nm<sup>3</sup> and 6 g NH<sub>3</sub> / Nm<sup>3</sup>. The assumption / parameters forming the backbone of the TCO elaboration are listed in the table below.

Please note that all units have been assumed without redundancies of the main process equipment. This assumption definitely has an effect in terms of reduced overall plant availability. However, this is true for both configurations and can therefore be neglected in this TCO comparison.

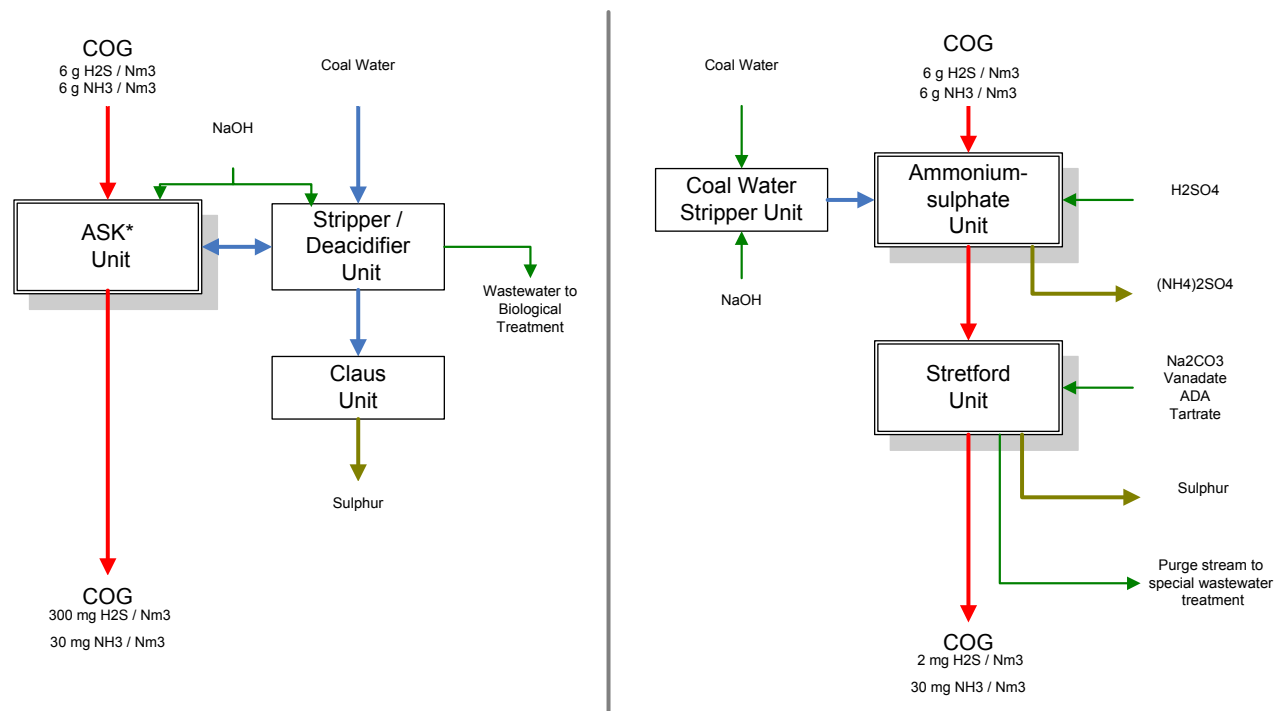

**Fig. 7: System Configurations**  
 \*ASK = Ammoniumsulfide Circuit Scrubber (Ammoniumsulfid-Kreislaufwäscher)

The special wastewater treatment unit for the contaminated purge stream has not been included in the TCO calculation, because reliable process data and costs could not be obtained. However, this treatment would lead to malus points in the TCO calculation for the wet oxidative process. The wastewater stream is loaded<sup>3</sup> with ca. 300 g/l thiocyanate [Hazard Code Xn (harmful to health)], 22.4 g/l thiosulphate [Hazard Code Xi (irritant)], 0.3 g/L vanadate [Hazard Code T (toxic)] und 0.6 g/l ADA [Hazard Code Xi (irritant)] and has to be treated with special care.

The data given for the Stretford process are based on operational data from RAG coke plant Grimberg, Germany, whereas the data for the ASK process are based on operational experience of various coke plants.

Parameter	Unit	Consumables Price	Ammonium Sulphate / Stretford Process	ASK / Stripping / Claus Process
Crude COG				
H <sub>2</sub> S	g/Nm <sup>3</sup>		6	6
NH <sub>3</sub>	g/Nm <sup>3</sup>		6	6
Clean COG				
H <sub>2</sub> S	mg/Nm <sup>3</sup>		2	300
NH <sub>3</sub>	mg/Nm <sup>3</sup>		30	30
Consumables				
Steam	t/d	11.90 €/t	154	264
Electricity	kWh/d	0.34 €/kWh	11,900	6,600
H <sub>2</sub> SO <sub>4</sub> (98%)	t/d	128.00 €/t	17.5	--
ADA	kg/d	7.70 €/kg	24	--
Vanadate	kg/d	27.00 €/kg	10	--
Tartrate	kg/d	5.50 €/kg	13	--
Soda	t/d	370.00 €/t	2.6	--
Caustic Soda	t/d	110.00 €/t	9,600	9,600
Products				
Sulphur	t/d		4.8	5.4
Ammonium sulphate	t/d		23.5	--
Revenues				
Sulphur	€/t		125	250
Ammoniumsulphate	€/t		180	--
Annual Debt Service on Capital Costs	%		11	11
Annual Maintenance on Capital Costs	%		4	4

**Tab. 4: Assumption / parameters of the TCO elaboration (on European basis)**

*the difference in sulphur production results from the utilization of sulphur froth for the sodium polysulfide solution preparation in the polysulfide generator*

<sup>3</sup> Material Data Safety Sheets acc. 1907/2006/EG, Article 31, are available via <http://www.eusdb.de>

A comparison of the TCO is presented in the figure below. In the TCO costs for energy (steam, electricity), chemicals, maintenance and debt service are calculated in EURO cent per Nm<sup>3</sup> of COG and are matched with the revenues from the product sales.

Consideration of the personnel costs is difficult as the operation of the units are managed by the shifts that are responsible for the whole by-product plant. It is assumed as first approach that the personnel costs are similar in both configurations and can thus be eliminated from the TCO calculation.

As can be derived from the figure both net operation costs are slightly different and in favour of the ASK process route. The net operation costs amount to 0.98 €ct / Nm<sup>3</sup> COG for the wet oxidation process route and 0.92 €ct / Nm<sup>3</sup> COG for the ASK process route. Debt service and maintenance cost (i.e. also the capital costs) range in the same magnitude, which is contributed to the costly ammonium sulphate plant on the one hand where high alloy steel is used for reasons of corrosion resistance. For the same reasons also high alloy steel is required in the stripper / deacidifier columns of the ASK process.

Differences can be recognised in the consumption of chemicals and energy. As the wet oxidation process route is mainly relying on chemical reactions the consumption of chemicals in the Ammoniumsulphate and Stretford plant is high, and so are the costs of this category. The ASK process route is based on reversible physical absorption mechanisms. The reversibility is secured by application of steam to split and strip the weak temporary compounds resulting from the scrubbing. Thus more energy in terms of LP steam is consumed. The energy costs of the wet oxidation process route reflect on the one hand the steam that is consumed for the coal water stripper and the autoclave and on the other hand the higher power consumption demanded by the electrical equipment such as pumps, blowers, centrifuges that are operated in the process.

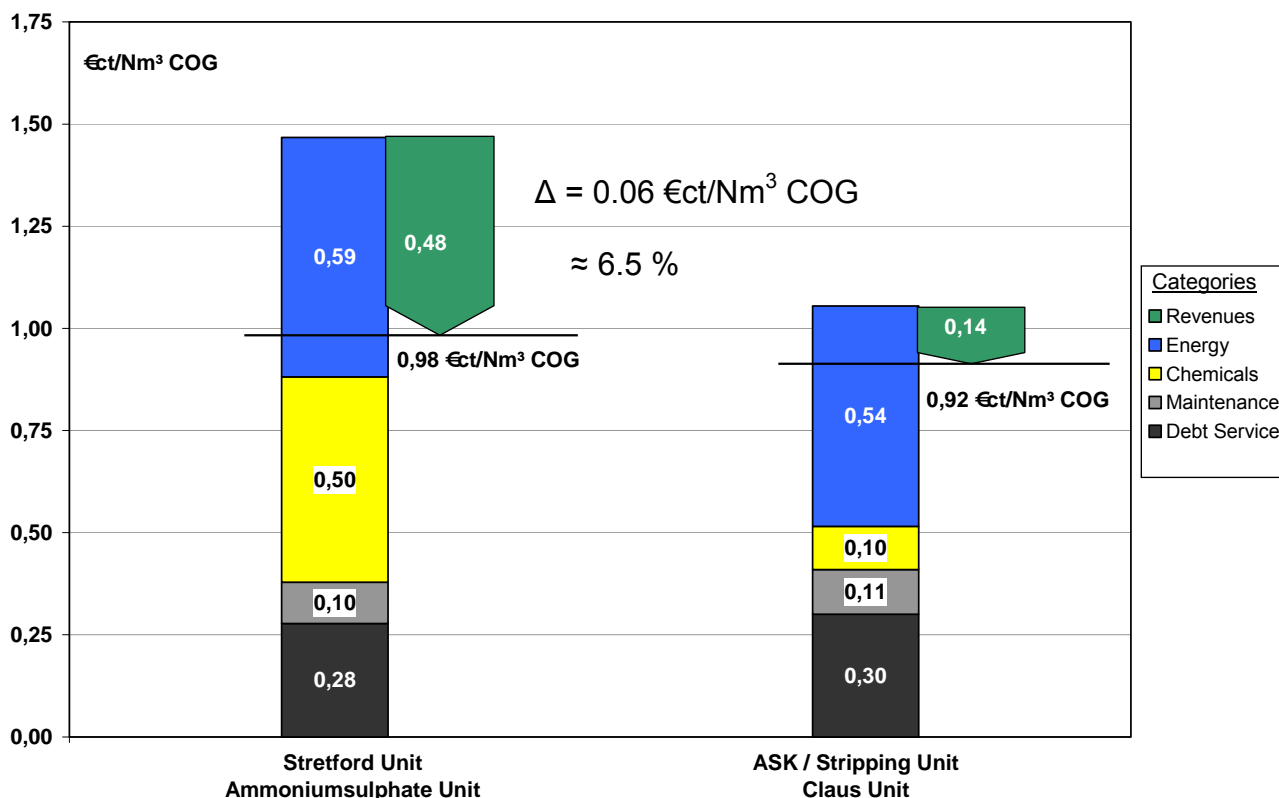

Fig. 8: TCO comparison between Stretford/Ammoniumsulphate Units and ASK/Stripping/Claus Units

The chemicals utilized in the ASK process comprise caustic soda for stripping fix ammonia from the coal water. The same is used in the wet oxidation process as well. Additionally the consumption of the sulfuric acid for the ammonia sulphate plant and the loss of Stretford chemicals through the purge stream and through the contamination of the product sulphur account for the costs in the category “chemicals”.

TCO calculations<sup>4</sup> with variations of the H<sub>2</sub>S load (6, 9 and 12 g/Nm<sup>3</sup>) and COG flow (50,000 and 100,000 Nm<sup>3</sup>/h) demonstrate that with increasing amount of H<sub>2</sub>S the Ammonium sulphate / Stretford process becomes more expensive relative to the ASK process due to the higher chemical consumption. The same holds true for the increase of the COG flow as the Ammonium sulphate / Stretford process has to be designed to handle the full flow of COG, whereas only the scrubbers in the ASK process have to be engineered accordingly. The rest of the process handles only vapours which volume flow is comparably less increasing than the increase of the COG flow.

The revenues mitigate the operational costs distinctly in case proper sale prices can be negotiated. Small variations in the revenues from product sales have a decisive effect on the TCO assessment. Commonly the quality of the Stretford sulphur is of deteriorated quality and is difficult to sell. In this TCO comparison it shows half of the sale price compared to the high quality, bright yellow sulphur of the Claus plant. However, if it comes worse and the Stretford sulphur can not be sold, it has even to be disposed of as dangerous (toxic) waste. The quality of the Claus sulphur is usually matching the quality demands of the chemical industry and is, hence, sold at a comfortable price. The ammonia sulphate is offered as an acid fertilizer in the agricultural industry. Depending on the need for acid fertilizers the price may vary from season to season depending on the crops planted in the respective season. Actually the price for ammonia sulphate is acceptable in Europe as acid fertilizers are used again in agriculture after the negative effects of acid rain (NO<sub>x</sub>, SO<sub>x</sub> emissions from industry and power generation) on soil have been remedied by time. In this TCO the revenues of the wet oxidation process route are dominated by the sale of ammonia sulphate.



**Fig. 9: Stretford sulphur after autoclave (left) / Claus sulphur (right)**

<sup>4</sup> Eisenhut, Werner Dr.: DMT internal report on TCO calculations for coke oven gas desulphurisation, 1969

The sulphur production from the Stretford unit is less than from the Claus-plant as it considers a slip stream of sulphur needed for the generation of the polysulphide for the HCN-scrubber.

The whole TCO calculation is based on European costing and prices. For this reason even the LP steam that is required for the stripping and heating processes has been associated with a price contributing sincerely to the operational costs.

In integrated steel plants LP steam is usually available in surplus quantities and free of charge from the steam network. Chemicals and electricity, however, have to be procured from external sources. In order to take this circumstance into account the following figure reveals the TCO comparison without associated costs for LP steam.

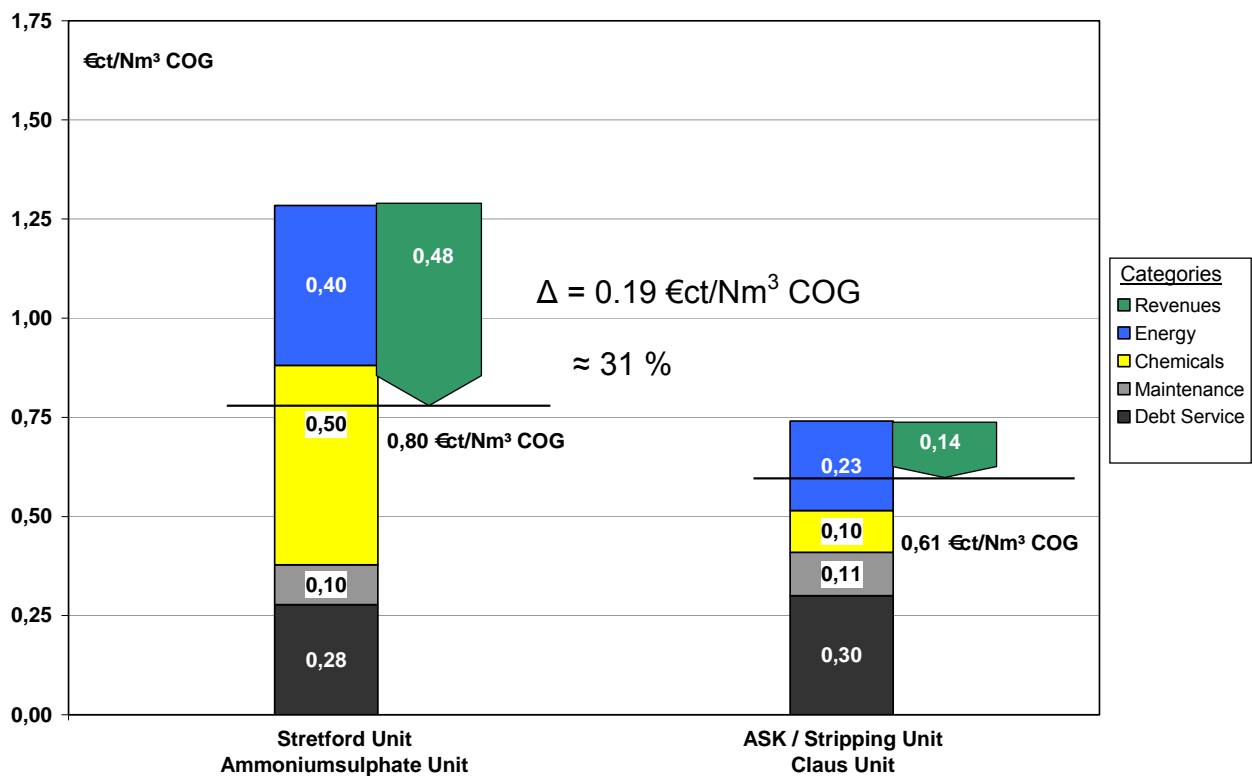

**Fig. 10: TCO comparison between Stretford/Ammoniumsulphate Units and ASK/Stripping/Claus Units considering LP steam availability free of charge**

As the LP steam costs contribute remarkably to the cost category “energy” in the ASK process the process becomes much more cost efficient compared to the wet oxidation process. The net operation costs amount to 0.80 €ct / Nm<sup>3</sup> COG for the wet oxidation process route and 0.61 €ct / Nm<sup>3</sup> COG for the ASK process route.

As detailed before the revenues depend on the achievable market price for the products. In Table 5 two further sale price scenarios (high and low level) are described for both process routes and compared to the above mentioned “medium level” scenario. All scenarios are calculated considering steam availability at costs and free of charge.

In the high and low level scenario the high and low ranges of the product sale prices achievable in Europe are considered. However, in both cases it is now reflected that Stretford sulphur is commonly not a saleable product. Hence, the sale price is considered to be zero.

Sale Scenario			Process Route	Cleaning Costs € ct / Nm <sup>3</sup> COG			
Scenario	(NH <sub>4</sub> ) <sub>2</sub> SO <sub>4</sub> €/t	S° €/t		Scenario (Steam at costs)	Δ	Scenario (Steam at no costs)	Δ
Medium level	180	125	Stretford	0.98	+7%	0.80	+31%
	---	250	ASK	0.92		0.61	
High level	180	---	Stretford	1.04	+18%	0.86	+51%
	---	320	ASK	0.88		0.57	
Low level	120	---	Stretford	1.19	+29%	1.00	+64%
	---	250	ASK	0.92		0.61	

**Tab. 5: Product Sale Scenario Impact on TCO (on European basis)**

As can be recognized the COG cleaning costs develop in all cases in favor of the ASK process.

Converting exemplarily the given costs for cleaning COG from the "low level sale scenario" into daily and annual costs it reads as follows for a COG throughput of 42,000 Nm<sup>3</sup>/h:

with steam at costs

Stretford route	12,000 €/d
ASK route	9,275 €/d
<b>Difference / day (24h)</b>	<b>2,725 €/d</b>
<b>Difference / year (360 d)</b>	<b>981,000 €/a</b>

with steam at no costs

Stretford route	10,080 €/d
ASK route	6,150 €/d
<b>Difference / day (24 h)</b>	<b>3,930 €/d</b>
<b>Difference / year (360 d)</b>	<b>1,414,800 €/a</b>

These figures impressively demonstrate that huge amounts of money can be saved by the coke plant operator by basing and taking decisions on TCO considerations.

## 6 Conclusions

The optimal COG cleaning process has to be carefully selected depending on the COG purity requirements in view of the perspective final utilization of the gas.

Wet oxidative processes such as the Stretford process in combination with an ammonium sulphate process require expensive chemicals for the gas cleaning. The cleaning efficiency is by far better than the absorption / stripping process will yield. Depending on the revenues to be received from sales of sulphur and ammonium sulphate products the Total Cost of Operation (TCO) is comparable to the ASK / Claus process. However, in case of free of charge availability of LP steam from the steam network in an integrated steel plant, the TCO becomes distinctly higher than those of the ASK / Claus process.

Absorption / stripping processes such as the ASK / Claus process mainly consume LP steam for the stripping process. In case of free of charge availability of LP steam from the steam network in an integrated steel plant, the ASK / Claus process becomes much more cost efficient compared to the wet oxidation process. However, the cleaning efficiency is much less (300 mg H<sub>2</sub>S / Nm<sup>3</sup> COG, 30 mg NH<sub>3</sub> / Nm<sup>3</sup> COG) compared to the Stretford / ammonium sulphate process (2 mg H<sub>2</sub>S / Nm<sup>3</sup> COG, 30 mg NH<sub>3</sub> / Nm<sup>3</sup> COG). The quality of the Claus sulphur is much better and prone to higher revenues when sold to the chemical industry.

The following table summarizes the main advantages and disadvantages of the two process routes under comparison on a glance.

Wet oxidative process		Absorption / stripping process	
Name	Description	Name	Description
Stretford / Ammonium sulphate process	H <sub>2</sub> S is scrubbed from the coke oven gas by a sodium carbonate solution (Na <sub>2</sub> CO <sub>3</sub> ) and elemental sulphur (S <sup>0</sup> ) is yielded using vanadate (VO <sub>3</sub> ) as an intermediate. Regeneration of the scrubbing liquid takes place by aeration (O <sub>2</sub> ), using anthraquinone disulphonic acid (ADA) as an intermediate.	ASK* / Stripping / Claus process	H <sub>2</sub> S is scrubbed from the coke oven gas by a NH <sub>3</sub> solution. The NH <sub>3</sub> solution is derived from the NH <sub>3</sub> scrubber. The H <sub>2</sub> S and NH <sub>3</sub> are stripped from the washing liquor by steam stripping and the vapours are led to a Claus plant.
	<u>Advantages:</u>		<u>Advantages:</u>
	<ul style="list-style-type: none"> <li>• High cleaning efficiency (&lt;2 mg H<sub>2</sub>S / Nm<sup>3</sup> COG, 30 mg NH<sub>3</sub> / Nm<sup>3</sup> COG)</li> <li>• No HP-scrubbing required</li> </ul>		<ul style="list-style-type: none"> <li>• Lower operating costs</li> <li>• No consumable catalyst required</li> <li>• NH<sub>3</sub>-scrubbing included</li> <li>• High quality Sulphur S<sup>0</sup> with high revenues</li> <li>• No contaminated wastewater; wastewater can be directly delivered to the biological treatment plant</li> </ul>
	<u>Disadvantages:</u>		<u>Disadvantages:</u>
	<ul style="list-style-type: none"> <li>• Higher operating costs</li> <li>• NH<sub>3</sub> and HCN pre-scrubbing required</li> <li>• Catalyst as consumable required</li> <li>• Quality of Sulphur S<sup>0</sup> often</li> </ul>		<ul style="list-style-type: none"> <li>• Lower cleaning efficiency (300 mg H<sub>2</sub>S / Nm<sup>3</sup> COG, 30 mg NH<sub>3</sub> / Nm<sup>3</sup> COG)</li> <li>• HP-scrubbing necessary to achieve a H<sub>2</sub>S concentration of below 2</li> </ul>

---

deteriorated yielding lower revenues	mg/Nm <sup>3</sup> in the clean gas (if demanded)
<ul style="list-style-type: none"><li>• Contaminated wastewater streams need special treatment</li><li>• Susceptible for contamination</li><li>• Dependence on suppliers for catalyst and ADA (consumables)</li></ul>	

---

**Tab. 6: Comparison of Wet oxidative process and Absorption / stripping process**  
**\*ASK = Ammoniumsulphide Circuit Scrubber (Ammoniumsulfid-Kreislaufwäscher)**

Concluding this paper it can be stated that the ASK process representing the absorption / stripping process route is a cost efficient and at the same time an environmentally sound way of cleaning COG.

## 7 Contact

DMT GmbH & Co. KG  
Cokemaking Technology Division  
Am Technologiepark 1  
45307 Essen  
Germany

email: [kt@dmtd.de](mailto:kt@dmtd.de)  
Phone: +49 201 172 1207  
Fax: +49 201 172 1241